



R2D18-120

Ø 180 mm wall ironers



ELECTRONIC CONTROL

Simple and user friendly : Start/stop button, selection of 4 temperatures
Preset ironing speeds, not adjustable



FEATURES

Large roll contact area with the linen
Roll lifting control by pedal
Two available models:

- Standard model: roll with cotton polyester coating
- Nomex Model: roll with Nomex coating



ROBUSTNESS

Nomex quality coating: resistant to high temperatures
Panels in grey skinplate and stainless steel
Wooden feeding board



EFFICIENCY

Acoustic comfort : <55 dB
Minimum space requirement: space saving, suitable for small spaces
Ideal for processing small quantity of flat linen in facilities like restaurants, guest rooms, hostels, etc.



MAINTENANCE

Easy installation : requires only an electrical connection
Easy access on both sides for maintenance



OTHERS

Front feeding and return
Roll Ø 180 mm
Working widths: 1.000 and 1.200 mm
Electric heating
CE certification



GENERAL DETAILS	UNIT.	R2D18-120
Theoretical production 20-25% humidity	Kg/h	20
	Lb/h	44,09
Roll Ø	mm	180
	Inch	7,09
Working width	mm	1.200
	Inch	39,37
Working speed	m/min	2,02
	ft/min	6,62
Nomex quality coating	-	NO
Electronic control	-	YES
Chest motion	-	Manual
POWER		
Heating power	Kw	4
Roll motor power	Kw	0,029
Fan motor power	Kw	-
Total electric power	Kw	4,029
CONNEXIONS		
Tension 230V I + N + T	n° x mm² /A	3 x 4 / 20A
	n° x AWG/A	3 x 11 / 20A
Tension 230V III + T	n° x mm² /A	N/A
	n° x AWG/A	N/A
Tension 400V III + N + T	n° x mm² /A	N/A
	n° x AWG/A	N/A
DIMENSIONS / DIMENSIONS WITH PACKAGING		
Net width / Gross width	mm	1.570 / 1.690
	Inch	62 / 67
Net depth / Gross depth	mm	438 / 540
	Inch	17 / 21
Net height / Gross height	mm	952 / 1.130
	Inch	37 / 44
Net weight / Gross weight	Kg	90 / 110
	Lb	198 / 243
Volume	m³	0,65 / 1,03
	ft³	22,95 / 36,37
OTHERS		
Number of fume outlets	NO	-
Ø fume outlets	mm	-
Air flow (suction)	m³/h	-
Noise level	dB	55

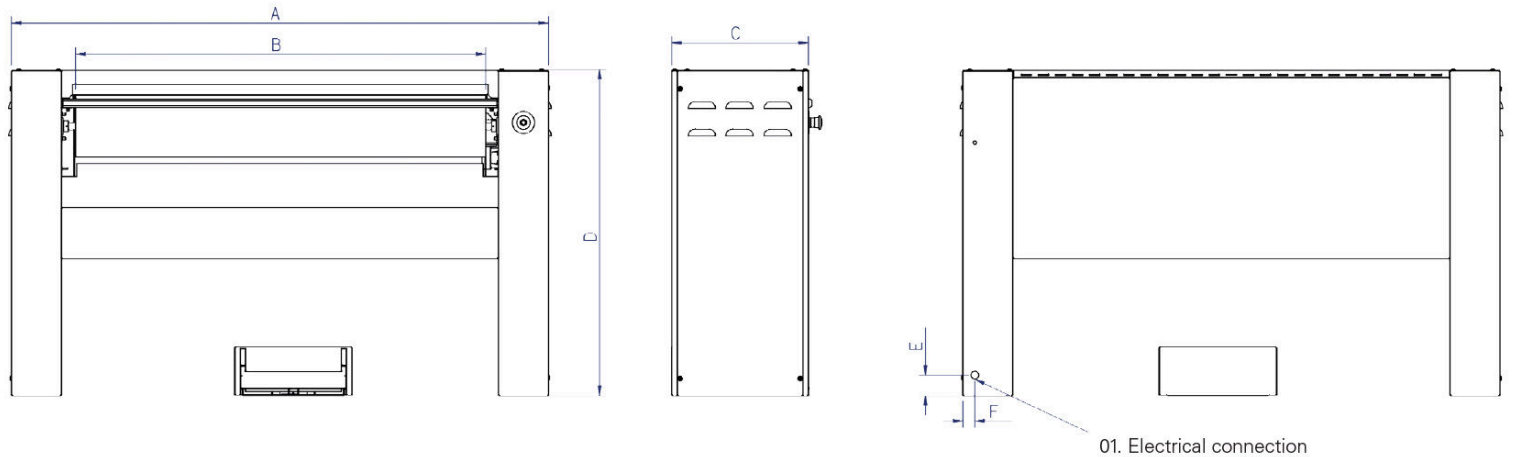

	A	B	C	D	E	F
R2D18/100	1370	1000	400	952	60	35
R2D18/120	1570	1200	400	952	60	35

