

# DD-23 HP GOLD ET2 GOLD HP dryers



## EASY TOUCH 2

User friendly and totally programmable with 7" coloured touch screen.  
USB Connection. PC software free of charge for programming, telemetry, data analysis, etc.  
Videos on display (ads, instructions, etc.)  
37 languages.



## FEATURES

Reversing drum as standard.  
Stainless steel drum as standard.  
Frequency inverter as standard.



## EFFICIENCY

DOUBLE AIRFLOW - mixed axial-radial airflow  
CARE DRY: humidity control.  
Big fluff filter.  
Double door glass.



## VERSATILITY

Make to order - customization  
WET CLEANING  
OPL > Multivending - Standard OPL model easily transformable to coin laundry uses.



## CONNECTIVITY

Danube Online communication - IoT  
Management of laundries: OPL and COIN  
Remote payment (coin laundry), remote technical service



## ERGONOMICS

Drawer as fluff filter, made of stainless steel.  
Biggest door diameters.  
Opening sense of door adjustable on site.

Hinged panel: easy and ergonomic access.  
Technical menu: statistics, alarm, autotest, data recovery for technicians and maintenance.



## MAINTENANCE

Grey skinplate outer casing, stainless steel look.  
SOFT DRY - drum with stamped holes.  
COOL DOWN - anti-wrinkle at the end of the cycle.  
No need of exhaust to the exterior.  
Low energy consumption.  
Water to refrigerate, which may be reused to wash.  
CE approved.



## OPTIONS

- IoT licence - Danube Online
- 230V 3~ 50 Hz HP
- 230V 3~ 60 Hz HP
- RD Opposite door opening 11-23
- TR Tropicalized model (ET2)
- SSC Stainless steel outer casing HP -23
- SSF Stainless steel front panel HP-23
- WB Wooden packing HP 23

TECHNICAL DATA	UNIT.	DD-23 HP GOLD ET2
Capacity 1/18	Kg	26
Capacity 1/20	Kg	23
Capacity 1/30	Kg	15
Hourly Output*	Kg/h	22,9
Evaporation capacity*	l/h	11,5
<b>DRUM</b>		
Ø Drum	mm	855
Drum length	mm	800
Drum volume	l	460
Ø Loading door	mm	574
<b>POWER</b>		
Drum motor power	kW	0,37
Fan motor power	kW	0,55
Electric heating power	kW	3,8 + 4***
Total electric power	kW	8,77
Electric consumption	kWh/l	1,05**
Nominal airflow	m <sup>3</sup> /h	1.200
<b>CONNEXIONS</b>		
Tension 400V - III + N + T (50 Hz)	Nº x mm <sup>2</sup> / A	5 x 4 / 20
Heat pump inlet (cooling)	BSP	1/2"
Heat pump outlet (cooling)	BSP	1/2"
Drain	BSP	3/4"
<b>DIMENSIONS / PACKING DIMENSIONS</b>		
Net width / Gross width	mm	890 / 970
Net depth / Gross depth	mm	1.590 / 1.720
Net height / Gross height	mm	1.812 / 1.940
Net weight / Gross weight	Kg	380 / 395
<b>OTHERS</b>		
Noise level	dB	64

\* it may vary depending on the type of heating, filter cleanliness or extraction type

\*\* kWh per litre of evaporated water

\*\*\* compressor + resistances

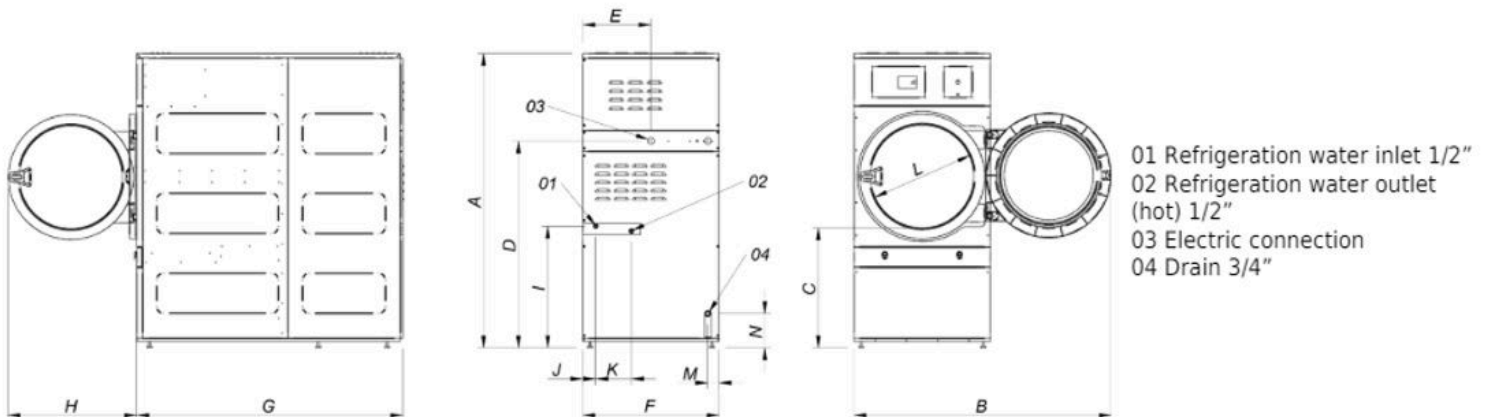

	A	B	C	D	E	F	G	H	I	J	K	L	M	N
DD-11 HP GOLD	1 694	1 447	689	1 190	392	785	1 255	735	700	75	205	575	67	197
DD-16-HP GOLD	1 694	1 447	689	1 190	392	785	1 525	735	700	75	205	575	67	197
DD-23 HP GOLD	1 812	1 552	743	1 190	445	890	1 595	735	700	127	205	575	119	250

