

DPR-10 EM

EM professional dryers



VERSATILITY

OPL <> SELF
SINGLE <> STACKED
Can be stacked with a WPR washer or another DPR dryer.
Reversible control panel (except Basic model)
Suitable for many sectors: hotels, gyms, campings, coin laundries, etc.



FEATURES

EM PROGRAMMER: selection of time and temperature, simple and versatile (standard or self-service version)
Reduced drying time (less than 45 minutes)
Heating: 6,75 kw, option 4,5 kw (except Basic model: power 4,5 kw only)



EFFICIENCY

Improved airflow system
Big fluff filter as drawer
Stacked machines: control panel can be inverted to the bottom for better ergonomics (except Basic)



ROBUSTNESS

Outer casing in grey skinplate (white lacquered panels on Basic model)
Sturdy door made in aluminium
Drawer as fluff filter: not in the door
Industrial fan and powerful airflow
Sturdy construction of the structure and panels



OTHERS

Galvanized drum
Integrated COOL DOWN: anti-wrinkle at the end of drying cycle
Basic model available in two versions: three-phase or single-phase model (not convertible)
Electric or gas heating (except BASIC models, only electric heating)
CE approved



OPTIONS

- Ergonomics plinth WPR-DPR - skinplate (except BASIC)
- Ergonomics plinth WPR-DPR -Stainless steel (except BASIC)
- NG Natural gas heated tumble dryer (LPG as standard)
- SSD Stainless steel drum AISI-304
- SSC Stainless steel outer casing DPR (Except BASIC)
- RD reverse door opening (Except BASIC)
- CU control panel in the bottom (except BASIC)
- Supl. 400V III /230 I/III 60HZ DPR 8-10
- Ergonomic plinth WPR-DPR - skinplate
- Supl 440-480V III 50/60 Marine DPR 8-10
- Ergonomic plinth WPR-DPR - stainless steel
- Several payment systems for self-service

CAPACITY & DRUM		UNIT.	DPR-10 EM	
Capacity 1/18		Kg	11,1	
		lb	24,5	
Capacity 1/20		Kg	10	
		lb	22	
Ø Drum		mm	590	
		inch	23,2	
Drum length		mm	690	
		inch	27,2	
Drum volume		l	200	
		cu ft	7,06	
Ø Door hole		mm	480	
		inch	18,90	
Door center height		mm	554	
		inch	21,8	
Height from floor to bottom of door		mm	250	
		inch	9,84	
ELECTRIC HEATING				
Evaporation capacity		L/h	6,35	
		US gallon/h	1,68	
Hourly output		Kg/h	12,5	
		lb/h	27,56	
Installed heating power		kW	4,5 / 6,75	
Installed electrical power		kW	4,92 / 7,17	
Drum motor power*		kW	0,37	
GAS HEATING				
Evaporation capacity		L/h	6,35	
		US gallon/h	1,68	
Hourly output		Kg/h	12,5	
		lb/h	27,56	
Installed gas heating power		kcal/h	5761	
		Btu/h	22861	
Installed gas heating power		kW	6,70	
Installed electrical power		kW	0,42	
Instant propane gas consumption (G31)		Kg/h	0,57	
		lb/h	1,26	
Instant natural gas consumption (G20)		m ³ /h	0,71	
		cfm	0,42	
Ø Gas inlet		BSPP ISO 228-1	1/2"	
VENTILATION				
Fan motor power*		kW	0,37	
Nominal air flow rate		m ³ /h	300	
		cfm	177	
Ø Fume exhaust		mm	100	
		inch	3,94	
HEAT EMISSION				
Maximum total heat emission		kW	0,5	
		Btu/h	1536	
Max. front heat emission		kW	0,3	
		Btu/h	1075	
CONNECTIONS				
Tension 230V - I + N + T		Nº x mm ² / A	E 3 x 10 / 40A	G 3 x 1,5 / 10A
Tension 230V - III + T		Nº x mm ² / A	4 x 4 / 25A	3 x 1,5 / 10A (1)
Tension 400V - III + N + T		Nº x mm ² / A	5 x 2,5 / 16A	3 x 1,5 / 10A (2)
DIMENSIONS / PACKING DIMENSIONS				
Net / gross width		mm	680 / 710	
		inch	26,8 / 28	



Net / gross depth	mm	775 / 832
	inch	30,5 / 32,8
Net / gross height	mm	1.056 / 1.141
	inch	41,6 / 44,9
Net / gross weight	Kg	93 / 111
	lb	204 / 245
OTHERS		
Sound level	dB	62

- *Single motor for drum and fan
(1) connect 2 phases and earth
(2) connect phase, neutral and earth

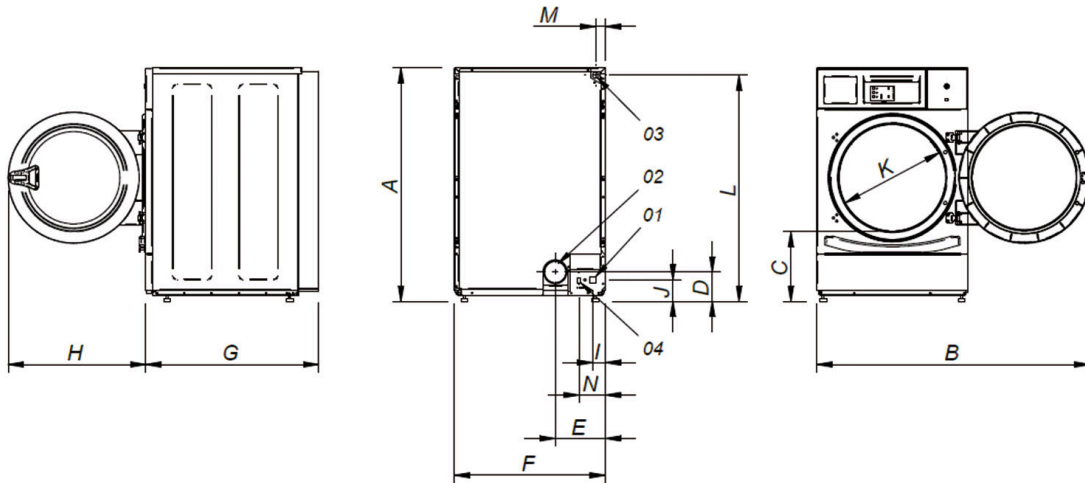

- 01. Electrical connection
- 02. Fume exhaust Ø 100 mm
- 03. Gas inlet 1/2" BSP
- 04. Ethernet connection (only with ET2 models)

	A	B	C	D	E	F	G	H	I	J	K	L	M	N
DPR-8	1 056	1 227	320	140	226	680	775	615	57	91	480	1 015	50	118
DPR-10	1 056	1 227	320	140	226	680	775	615	57	91	480	1 015	50	118

