

STD-14 BRONZE XP EM

STD BRONZE XP stack dryers



ELECTRONIC CONTROL

Easy-to-use electronic control with push buttons to control temperature and time



FEATURES

Reversing drum action as standard
Stainless steel drum as standard
Frequency inverter as standard



EFFICIENCY

DOUBLE FLOW - mixed axial-radial airflow
Big fluff filter



VERSATILITY

Make to order - customisation
OPL > Multivending - Standard OPL model easily trasformable to coin laundry use



ERGONOMICS

Drawer as fluff filter, stainless steel mesh
Biggest door diameters



MAINTENANCE

Hinged control panel: easy and ergonomic access
Technical menu: statistics for technicians and maintenance with external console (option)
Easy access to components



OTHERS

Grey skinplate outer casing, stainless steel look
SOFT DRY - new drum with stamped holes
COOL DOWN - anti-wrinkle at the end of the cycle
Electric or gas heating (except STD-22 XP model: only gas)
CE approved



OPTIONS

- DG Double door glass STD (1 unit per stack)
- BMS New display for EM programmer (2 units for STD)
- F03 Fluff filter with grid 0,3 mm (standard is 0,6 mm STD)
- NG Natural gas heated tumble dryer (LPG as standard)
- SSC Stainless steel outer casing (AISI-304) 14 STD
- 400V 3~ 50 Hz STD-11-18
- SSF Stainless steel front panel AISI-304 STD 11-14-18
- 400V 3N 60 Hz STD-11-35
- 400V 3~60Hz STD-11-22
- 230V 3~ 60 Hz STD-11-18 G
- 230V 3~ 60 Hz STD-11-18 E
- WB Wooden packing STD-14
- 440V/480V 3~ 60 Hz STD-11-22
- Several payment systems for self-service

CAPACITY & DRUM		UNIT.	STD-14 BRONZE XP EM	
Capacity 1/18		Kg	15 x 2	
		lb	33,1 x 2	
Capacity 1/20		Kg	13,5 x 2	
		lb	29,8 x 2	
Ø Drum		mm	750	
		inch	29,5	
Drum length		mm	610	
		inch	24,02	
Drum volume		l	270	
		cu ft	9,53	
Ø Door hole		mm	574	
		inch	22,6	
Door center height		mm	547 / 1522	
		inch	21,54 / 59,92	
Height from floor to bottom of door		mm	189 / 1164	
		inch	7,32 / 45,83	
ELECTRIC HEATING				
Evaporation capacity *		L/h *	14,5 x 2	
		US gallon/h *	3,83 x 2	
Hourly output**		Kg/h **	29 x 2	
		lb/h **	64 x 2	
Installed heating power		kW	18 x 2	
Installed electrical power		kW	37,34	
Drum motor power		kW	0,37 x 2	
GAS HEATING				
Evaporation capacity*		L/h	15,7 x 2	
		US gallon/h	4,14 x 2	
Hourly output **		Kg/h	31,4 x 2	
		lb/h	69,2 x 2	
Installed gas heating power		kcal/h	17627 x 2	
		Btu/h	69996 x 2	
		kW	20,5 x 2	
Installed electrical power		kW	1,34	
Instant LPG gas consumption (G31)		Kg/h	1,76 x 2	
		lb/h	3,88 x 2	
Instant natural gas consumption (G20)		m³/h	2,17 x 2	
		cfm	1,28 x 2	
Ø Gas inlet		BSPP ISO 228-1	3/4"	
VENTILATION				
Fan motor power		kW	0,25 x 2	
Nominal air flow rate		m³/h	500 x 2	
		cfm	294,28 x 2	
Ø Fume exhaust		mm	200	
		inch	7,87	
HEAT EMISSION				
Maximum total heat emission		kW	3,3	
		Btu/h	11198	
Max. front heat emission		kW	1,2	
		Btu/h	4199	
CONNECTIONS			E	G
Tension 230V - I + N + T		Nº x mm² / A	-	3 x 2,5 / 16A
Tension 230V - III + T		Nº x mm² / A	4 x 50 / 125A	3 x 2.5 / 16A (5*)
Tension 400V - III + N + T		Nº x mm² / A	5 x 16 / 63A	3 x 2.5 / 16A (6*)
NET DIMENSIONS / PACKING DIMENSIONS				
Net / gross width		mm	785 / 865	
		inch	30,9 / 34,1	



Net / gross depth	mm	1135 / 1218
	inch	44,7 / 48
Net / gross height	mm	1994 / 2126
	inch	78,5 / 83,7
Net / gross weight	Kg	299 / 312
	lb	659 / 688
OTHERS		
Max. sound level (1 m in front)	dB	64

* Drying conditions: full load (1/20) of towels, drying temperature 90°C.

** Kg dry linen per hour, according to the above drying conditions.

(5*) Connect 2 phases and earth

(6*) Connect phase, neutral and earth

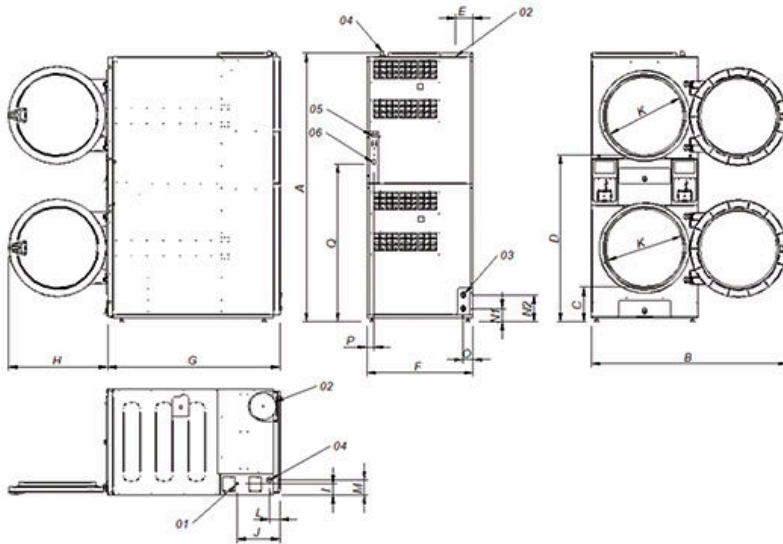

- 01. Power supply
- 02. Fumes extraction \varnothing 200 mm
- 03. 2 sprinkler valves 3/4"
- 04. Gas inlet 1/2"
- 05. Ethernet connection (ET2 model only)
- 06. ON/OFF control switch

		A	B	C	D	E	F	G	H	I	J	K	L	M	N1	N2	O	P	Q
STD-11 XP	mm	1980	1447	259	1234	131	785	1001	735	83	318	575	77	113	97	197	73	54	1163
STD-14 XP	mm	1980	1447	259	1234	131	785	1135	735	83	318	575	77	113	97	197	73	54	1163
STD-18 XP	mm	1980	1447	259	1234	131	785	1271	735	83	318	575	77	113	97	197	73	54	1163

