

D-16 BM

Ø 325 mm flatwork ironers



## ELECTRONIC CONTROL

BM control, simple and user friendly, 2 selectable operating modes:

AUTO mode : automatic management of ironing speed according to the selected temperature.

MANUAL mode: selection of temperature and speed



## EFFICIENCY

Good heat conduction thanks to the roll material and thickness: greater control of energy expenditure

Automatic shutdown at 80°C (adjustable parameter)

Fumes circulation circuit from the bottom reducing energy consumption



## ROBUSTNESS

Roll driving by speed inverter

Nomex quality feeding and ironing belts: high temperatures resistant

Panels in skinplate and stainless steel

Coiled felt for greater lifespan

Nickel plate roll as option: anticorrosive, more durable



## ERGONOMICS

Acoustic comfort : <65 dB

Appropriate operating height: 990 mm feeding belts

Minimal encumbrance: space saving, suitable for most spaces

Electronic control with Auto mode: easy to use, optimized ironing speed



## MAINTENANCE

Easy access to all components on both sides of the machine

Basic connections : electrical connection and air extraction



## OTHERS

Dries and irons flat linen from a high spin washer extractor in a single operation

Front feeding and return

Built-in cool down system

Polished steel roll Ø 325 mm

Working widths: 1.400, 1.600 and 2.000 mm

Electric or atmospheric gas heating

CE standard

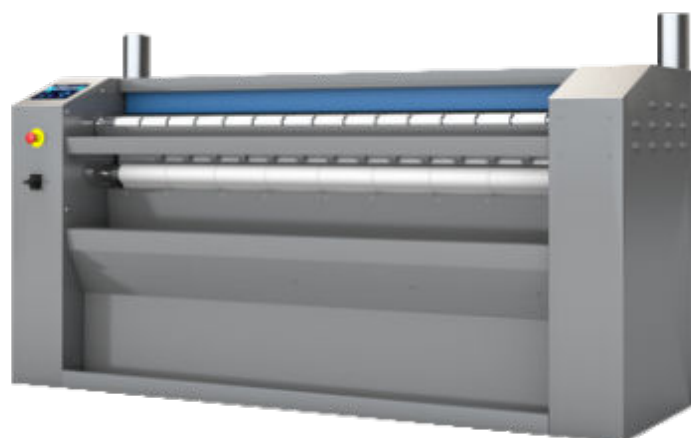

## OPTIONS

- IMC CARE IRON humidity control - Ø 325 mm
- NI Nickel plate roll D-16
- WM Maritime Wood packaging for DII-16
- 230V I N 50 Hz (D-16 BM G)
- 230V I N 60 Hz (D-16 BM G)
- 230V III 50-60 Hz (D-16 BM E)
- 440V 50-60 Hz (D-16 BM E)

GENERAL DETAILS	UNIT.	D-16 BM	
Theoretical production Electric heating*	Kg/h	30	
	lb/h	66	
Theoretical production Gas atmo heating*	Kg/h	32	
	lb/h	71	
Theoretical production Radiant gas heating*	Kg/h	N/A	
	lb/l	N/A	
Roll Ø	mm	325	
	inch	12,80	
Working width	mm	1.600	
	inch	63,0	
Height floor-feeding belts	mm	990	
	inch	39,0	
Working speed	m/min	1,5-10	
	ft/min	4.9-32	
Electronic control	-	YES	
No. Programs	-	2	
Length folder	-	NO	
Large surface contact with linen	-	270°	
POWER			
Electric mod.: heating power	Kw	16,2	
Electric mod: Total electric power	Kw	16,57	
Gas mod.: heating power	Kw	22,5	
Gas mod.: total electric power	Kw	0,37	
Steam mod. : heating power	Kg/h	-	
Roll motor power	Kw	0,28	
Fan motor power	Kw	0,12	
CONNECTIONS		E	G
Tension 230V - I + N + T	Nº x mm² / A	N/A	3 x 2,5 / 6A
	nº x AWG/A	N/A	3 x 13 / 6A
Tension 230V - III + T	Nº x mm² / A	4 x 10 / 50A	4 x 2,5 / 6A
	nº x AWG/A	4 x 7 / 50A	3 x 13 / 6A
Tension 400V - III + N + T	Nº x mm² / A	5 x 6 / 25A	5 x 2,5 / 6A
	nº x AWG/A	5 x 9 / 25A	5 x 13 / 6A
Ø Gas inlet	BSP	1/2"	
Ø Steam inlet	BSP	-	
Ø Condensed (Steam models)	BSP	-	
OVERALL DIMENSIONS / PACKING DIMENSIONS			
Net width / Gross width	mm	2.202 / 2.340	
	inch	86,7 / 92,1	
Net depth / gross depth	mm	686 / 770	
	inch	27 / 30,3	
Net height / gross height	mm	1.112 / 1.400	
	inch	43,8 / 55,1	
Net weight / gross weight	kg	385 / 405	
	lbs	849 / 893	
Net volume / Gross volume	m³	1,68 / 2,52	
	ft³	59,32 / 89,08	
OTHERS			
No. Fume outlet	Nº	1	
Ø Fume outlet	mm	98	
	inch	3,86	
Air Flow	m³/h	500	
	cfm	294	
Sound level	dB	60	
Capacité d'évaporation (max)	l/h	13,5	
	USgallon/h	3,6	
Additional ELECTRIC POWER for folder option	-	-	



Additional ELECTRIC POWER for folder + rear exit option	-	-
---	---	---

\* Theoretical production with 45% moisture

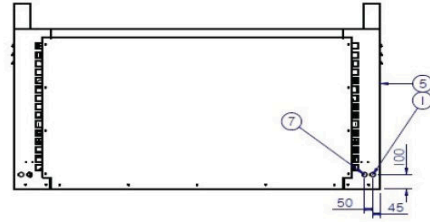
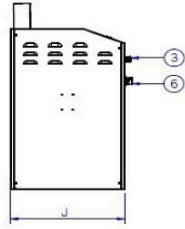
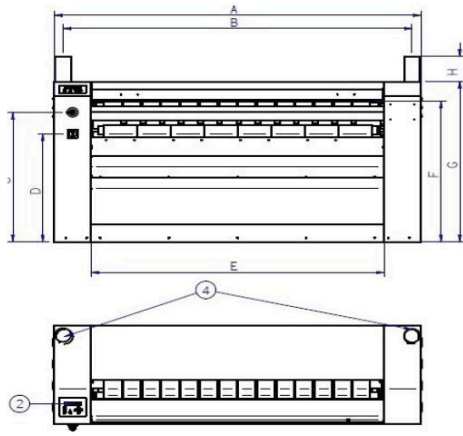

- 01. Electrical connection
- 02. BM Control
- 03. Emergency stop
- 04. ø 98 mm extraction
- 05. Crank
- 06. Main switch

	A	B	C	D	E	F	G	H	I	J
D-14 BM	1.952	1.846	900	750	1.510	980	1.112	140	746	686
D-16 BM	2.202	2.096	900	750	1.760	980	1.112	140	746	686
D-20 BM	2.552	2.446	900	750	2.110	980	1.112	140	746	686

