

SP600-2600

SP compact ironers

FEATURES

SP models are ironers that dries, irons and folds with a lengthwise folder making up to two length folds.

- Roll dimensions: working width 2m60 and 3m30, ø 600, 800 or 1000 mm.
- 1 or 2 length folds with 2 independent lanes
- Folding by photocells and compressed air
- Frequency inverter.
- Feeding and ironing by Nomex quality belts.
- Panels in white painted steel.
- Polished steel roll with fingers guard.
- Touch screen control: programs can be created with temperature and speed control:
 - between 3 and 10 m/min (ø 600 mm)
 - between 3 and 13 m/min (ø 800 mm)
 - between 4 and 18 m/min (ø 1000 mm)
- Big output capacity: depending on the residual moisture of the linen, straight from a high spin washer extractor:
 - up to 140 kg/h (ø 600 mm)
 - up to 220 kg/h (ø 800 mm)
 - up to 290 kg/h (ø 1000 mm)
- Electric, gas or steam heating
- Powerful exhaust system
- Compressed air connexion required: pressure 6,5 bar



OPTIONS

- Vacuum belts to help linen feeding
- Automatic 1 lane clamp feeder (requires vacuum feeding belts option)
- Rear exit with table (SP 600 H=610 mm, SP800 H=540 mm). Requires by-pass option
- Crossfolder CPL-CROSS 260 + stacker
- Crossfolder CPL-CROSS 330 + stacker
- Motorized rear exit - height 860 mm (requires by-pass option)
- 2 lanes rear collector for small items (requires rear exit + by-pass option)
- 4 lanes rear collector for small items (requires rear exit + by-pass option)
- By-pass for rear exit
- Double air pressure in length folds for thicker linen
- Dirty or torn linen rejection system (buttons)
- Different voltage from 400V III +N 50Hz
- Maritime packing for SP

GENERAL DATA	UNIT.	SP600-2600
Theoretical production elec/steam	Kg/h	75-105
Theoretical production gas heating*	Kg/h	75-105
Theoretical production radiant gas burner (+20%)*	Kg/h	90-126
Ø Roll	mm	600
Working width	mm	2.600
Height floor-feeding	mm	1.050
Working speed	m/min	3-12
Control type	-	Digital
No. of programs	Nº.	20
MAIN FUNCTIONS		
Drying	-	YES
Ironing	-	YES
Longitudinal folding	-	YES
Cross folding	-	NO
Lateral stacking (Roll-Off or compact stacker)	-	NO
FOLDING		
1 lane - lengthfold	Nº.	1-2
1 lane - crossfold	Nº	NO
2 lanes - lengthfold	Nº	1-2
2 lanes - crossfold	Nº	NO
4 lanes - crossfold	Nº	NO
4+ lanes	Nº	NO
POWER		
Electric model - Consumption	A	78
Electric model - Heating power	kW	54
Electric model - Total electrical power	kW	55,9
Steam model - Consumption	Kg/h	95
Steam model - Power (max 12 bar)	kW	55
Steam model - Total electrical power	kW	1,9
Liquefied gas (LPG) model - Consumption	m³/h	2,50
Liquefied gas (LPG) model - Power	kW	67,40
Natural gas (NG) model - Consumption	m³/h	6,70
Natural gas (NG) model - Power	kW	63,3
Gas LPG / NG model - Total electrical power	kW	1,9
CONNECTIONS		
Ø Gas inlet	BSP	1"
Ø Steam inlet (12 bar max.)	BSP	1"
Ø Condensed (steam models)	BSP	1/2"
Ø Air inlet	mm	12
DIMENSIONS		
Net width / gross width	mm	3.670 / 3.830
Net depth / gross depth	mm	1.440 / 1.620
Net height / gross height	mm	2.030 / 1.960
Net weight / gross weight	Kg	2.050 / 2.300
Volume	m³	10,73 / 12,16
OTHERS		
Exhaust outlet	Nº	2
Exhaust outlet Ø	mm	120
Air extraction flow rate	m³/h	2 x 630
Air consumption (6.5 bar)	NI/h	7.000
Noise level	dB	<80

*50% residual moisture, 140gr / m2 cotton,100% roll use



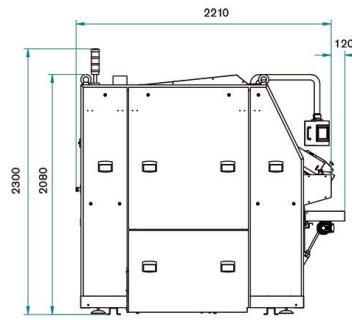
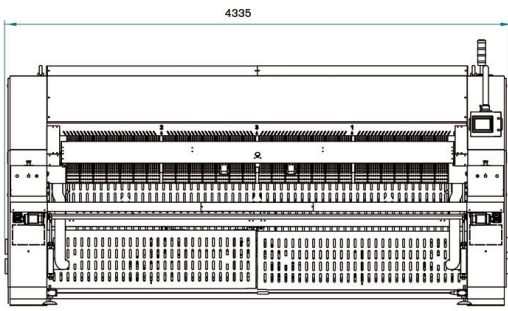

Standard :

- ST 1 - Warning light
- ST 2 - Emergency stop
- ST 3 - Lifting eye bolts (crane)
- ST 4 - Exhaust outlet

Options :

- OP 1 - not available for SP / S ranges
- OP 2 - Vacuum feeding belts
- OP 3 - Clamps feeder
- OP 4 - Linen reject button (SP)
- OP 6 - 2 or 4 lanes collector
- OP 31 - Brush guide feeder
- NO - not available for SP / S ranges

