



R3D25/140 GOLD GOLD ø 250 mm wall ironers



ELECTRONIC CONTROL

BM control: simple and user friendly with an AUTO mode, automatic management of ironing speed according to the selected temperature.
Digital speed and temperature display



FEATURES

Large roll contact area with the linen
Operation mode identical to a flatwork ironer: no roll lifting, more ergonomic
Models equipped as standard with Nomex belts, suction and variable speed inverter: more productivity
Adjustable speed and temperature



ROBUSTNESS

Nomex coating as standard: resistant to high temperatures
Panels in grey skinplate and stainless steel
Wooden feeding board
New kinematics, better reliability
Industrial components, more durable



EFFICIENCY

Acoustic comfort : max. 60 dB
Minimum space requirement: space saving, suitable for small spaces
Ideal for processing small quantity of flat linen in facilities like restaurants, guest rooms, etc.



MAINTENANCE

Easy installation : requires only an electrical connection
Easy access on both sides for maintenance
Quick and easy dismantling of bearings



OTHERS

Front feeding and return
Roll ø 250 mm
Working widths: 1.400 and 2.000 mm
Electric heating
CE certification



OPTIONS

- 230V III + N + T 50/60Hz GOLD models)

GENERAL DETAILS	UNIT.	R3D25/140 GOLD
Theoretical production 20-25% humidity	Kg/h	42
	Lb/H	92,59
Roll Ø	mm	250
	Inch	9,84
Working width	mm	1.400
	Inch	55,12
Working speed	m/min	1,5-6
	ft/mn	4,9 - 19,6
SC speed control (option)	m/min	--
	ft/mn	--
Nomex quality coating	-	YES
Electronic control	-	YES
Chest motion	-	NO
POWER		
Heating power	Kw	7
Roll motor power	Kw	0,18
Fan motor power	Kw	0,12
Total electric power	Kw	7,3
CONNEXIONS		
Tension 230V I + N + T	n° x mm ² /A	N/A
	n° x AWG/A	N/A
Tension 230V III + T	n° x mm ² /A	4 x 6 / 20A
	n° x AWG/A	4 x 9 / 20A
Tension 400V III + N + T	n° x mm ² /A	5 x 4 / 16A
	n° x AWG/A	5 x 11 / 16A
DIMENSIONS / PACKING DIMENSIONS		
Net width / Gross width	mm	1.923 / 1.890
	Inch	73 / 74
Net depth / Gross depth	mm	484 / 540
	Inch	19 / 21
Net height / Gross height	mm	985 / 1.130
	Inch	39 / 44
Net weight / Gross weight	Kg	154 / 174
	Lb	340 / 384
Volume	m ³	0,92 / 1,15
	fr3	32,38 / 40,73
OTHERS		
Number of fume outlets	Nb	1
Ø fume outlets	mm	80
	Inch	3,15
Air flow (suction)	m3/h	500
	cfm	294
Noise level	dB	60

*Dismantling of the extraction on left side for packaging



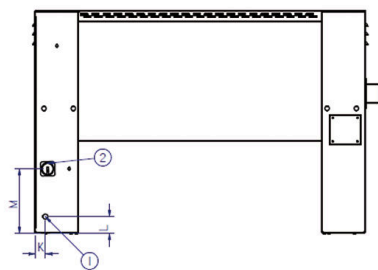
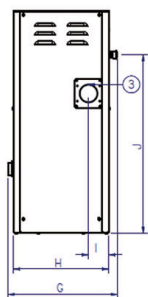
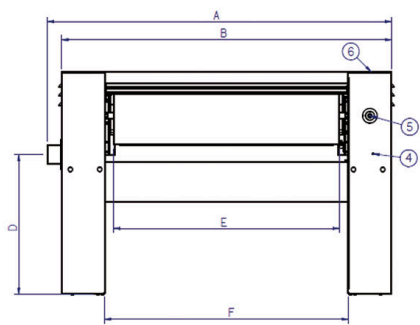

1. Electrical connection
2. Main switch
3. Extraction \varnothing 80 mm
4. Crank
5. Emergency stop
6. BM control

	A	B	C	D	E	F	G	H	I	J	K	L	M
R3D25/140 GOLD	1 923	1 862	985	610	1 400	1 480	484	423	91	791	45	75	287
R3D25/200 GOLD	2 523	2 462	985	610	2 000	2 080	484	423	91	791	45	75	287

