



S800-2600
S compact ironers

FEATURES

S models are ironers that dry and iron only, without any folding devices

- Roll dimensions: working width 2m60 and 3m30, \varnothing 600, 800 or 1000 mm.
- Frequency inverter.
- Feeding and ironing by Nomex quality belts.
- Panels in white painted steel.
- Polished steel roll with fingers guard.
- Touch screen control: programs can be created with temperature and speed control:
 - between 3 and 10 m/min (\varnothing 600 mm)
 - between 3 and 13 m/min (\varnothing 800 mm)
 - between 4 and 18 m/min (\varnothing 1000 mm)
- Big output capacity: depending on the residual moisture of the linen, straight from a high spin washer extractor:
 - up to 140 kg/h (\varnothing 600 mm)
 - up to 220 kg/h (\varnothing 800 mm)
 - up to 290 kg/h (\varnothing 1000 mm)
- Electric, gas or steam heating
- Powerful exhaust system
- Compressed air connexion required: pressure 6,5 bar



OPTIONS

- Vacuum belts to help linen feeding
- Automatic 1 lane clamp feeder (requires vacuum feeding belts option)
- Rear exit
- Motorized rear exit - height 860 mm. (rear exit included)
- Small pieces back collector: 2 lanes (requires rear exit option)
- Small pieces back collector: 4 lanes (requires rear exit option)
- Different voltage from 400V III +N 50Hz
- Maritime packing for S

GENERAL DATA	UNIT.	S800-2600
Theoretical production* elec/steam	Kg/h	140-175
Theoretical production gas heating*	Kg/h	140-175
Theoretical production* radiant gas burner	Kg/h	168-210
Ø Roll	mm	800
Working width	mm	2.600
Height floor-feeding	mm	1.050
Working speed	m/min	3-14
Control type	-	Digital
No. of programs	Nº.	20
MAIN FUNCTIONS		
Drying	-	YES
Ironing	-	YES
Longitudinal folding	-	NO
Cross folding	-	NO
Lateral stacking (Roll-Off or compact stacker)	-	NO
FOLDING		
1 lane - lengthfold	Nº.	NO
1 lane - crossfold	Nº.	NO
2 lanes - lengthfold	Nº.	NO
2 lanes - crossfold	Nº.	NO
POWER		
Electric model - Consumption	A	104
Electric model - Heating power	kW	72
Electric model - Total electrical power	kW	74,2
Steam model - Consumption	Kg/h	150
Steam model - Power (max 12 bar)	kW	85
Steam model - Total electrical power	kW	2,2
Liquefied gas (LPG) model - Consumption	m³/h	3,40
Liquefied gas (LPG) model - Power	kW	91,70
Natural gas (NG) model - Consumption	m³/h	9,20
Natural gas (NG) model - Power	kW	86,95
Gas LPG / NG model - Total electrical power	kW	2,2
CONNECTIONS		
Ø Gas inlet	BSP	1"
Ø Steam inlet (12 bar max.)	BSP	1"
Ø Condensed (steam models)	BSP	1/2"
Ø Air inlet	mm	12
DIMENSIONS		
Net width / gross width	mm	3.790 / 3.900
Net depth / gross depth	mm	1.770 / 2.280
Net height / gross height	mm	2.200 / 2.140
Net weight / gross weight	Kg	2.350 / 2.700
Volume	m³	14,76 / 19,03
OTHERS		
Exhaust outlet	Nº	2
Exhaust outlet Ø	mm	160
Air extraction flow rate	m³/h	2 x 1400
Air consumption (6.5 bar)	NI/h	5.000
Noise level	dB	<80

*50% residual moisture, 140gr / m2 cotton,100% roll use



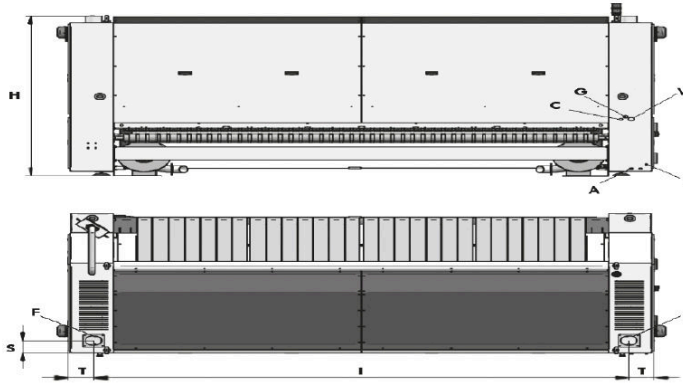
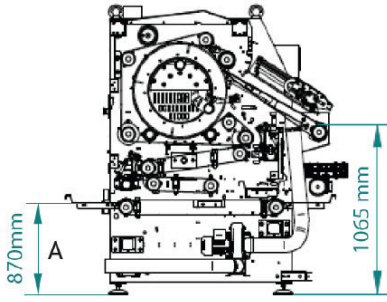
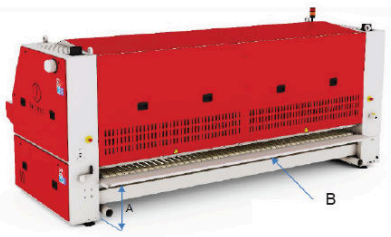

- A. Compressed air inlet
- B. Rear collector
- C. Condensed discharge (steam model)
- E. Electrical connection
- F. Fumes extraction
- G. Gas inlet
- V. Steam inlet

	H	I	T	S	A	C	E	F	G	V
S800-2600	1.966	3.242	186	152	∅ 12	1/2"	5 x 2,5	∅ 120	1"	1"
S800-3300	1.966	3.942	186	152	∅ 12	1/2"	5 x 2,5	∅ 120	1"	1"

