



# DPR-10 ET2

## ET2 professional dryers



### EASY TOUCH 2

User friendly and totally programmable 4,3"  
USB Connection. Online platform free of charge for programming, telemetry, data analysis...thanks to the IoT  
Videos on display (ads, instructions, etc.)  
37 languages  
8 dosing signals as standard



### VERSATILITY

OPL <> COIN  
SINGLE <> STACKED  
Models can be stacked on top of a washer or on another dryer.  
Control panel can be assembled between both drums for better ergonomics.  
Ideal for multiple solutions: hotels, campings, coin laundries, gyms, etc.  
Ready to be used with WET CLEANING programs



### FEATURES

Reduced drying times (less than 45 minutes)  
6,75 kw heating, option 4,5 kw



### CONNECTIVITY

**IoT - Danube online standard.**  
Management of laundries: OPL and COIN  
Remote payment



### EFFICIENCY

Optimised airflow system  
Axial airflow  
Wide fluff filter as drawer  
Efficient design



### ROBUSTNESS

Outer casing in grey skinplate  
Robust aluminium big door  
Industrial fan and powerful airflow  
Sturdy construction of the dryer structure and panels



### OTHERS

Gas or electric heated models  
Galvanized drum, grey skinplate panels  
CE approved



### OPTIONS

- IoT licence - Danube Online
- Several payment systems for self-service
- Ergonomics plinth WPR-DPR - skinplate (except BASIC)
- Ergonomics plinth WPR-DPR -Stainless steel (except BASIC)
- SSD Stainless steel drum AISI-304
- SSC Stainless steel outer casing DPR (Except BASIC)
- RD reverse door opening (Except BASIC)
- CU control panel in the bottom (except BASIC)
- TR Tropicalized model (ET2)
- IMC CARE DRY Humidity control (ET2)
- FEX Sprinkler fire extinguisher DPR
- NG Natural gas heated tumble dryer (LPG as standard) DPR
- OC Complete container order DPR + compact packing
- Ergonomic plinth WPR-DPR - skinplate
- Supl. 400V III /230 I/III 60HZ DPR 8-10
- Ergonomic plinth WPR-DPR - stainless steel
- Supl 440-480V III 50/60 Marine DPR 8-10

CAPACITY & DRUM		UNIT.	DPR-10 ET2	
Capacity 1/18		Kg	11,1	
		lb	24,5	
Capacity 1/20		Kg	10	
		lb	22	
Ø Drum		mm	590	
		inch	23,23	
Drum length		mm	690	
		inch	27,17	
Drum volume		l	200	
		cu ft	7,06	
Ø Door hole		mm	480	
		inch	18,90	
Door center height		mm	554	
		inch	21,81	
Height from floor to bottom of door		mm	250	
		inch	9,84	
ELECTRIC HEATING				
Evaporation capacity		L/h	6,35	
		US gallon/h	1,68	
Hourly output		Kg/h	12,5	
		lb/h	27,6	
Installed heating power		kW	6,75 (1)	
Installed electrical power		kW	7,17 (1)	
Drum motor power		kW	0,37 (2)	
GAS HEATING				
Evaporation capacity		L/h	6,35	
		US gallon/h	1,677	
Hourly output		Kg/h	12,5	
		lb/h	27,6	
Installed gas heating power		kcal/h	5761	
		Btu/h	22861,3	
Installed gas heating power		kW	6,70	
Installed electrical power		kW	0,42	
Instant propane gas consumption (G31)		Kg/h	0,57	
		lb/h	1,26	
Instant natural gas consumption (G20)		m <sup>3</sup> /h	0,71	
		cfm	0,42	
Ø Gas inlet		BSPP ISO 228-1	1/2"	
VENTILATION				
Fan motor power		kW	0,37(2)	
Nominal air flow rate		m <sup>3</sup> /h	300	
		cfm	176,57	
Ø Fume exhaust		mm	100	
		inch	3,94	
HEAT EMISSION				
Maximum total heat emission		kW	0,45	
		Btu/h	1536,4	
Max. front heat emission		kW	0,32	
		Btu/h	1075,5	
CONNECTIONS				
Tension 230V - I + N + T		Nº x mm <sup>2</sup> / A	E 3 x 10 / 40A	G 3 x 1,5 / 10A
Tension 230V - III + T		Nº x mm <sup>2</sup> / A	4 x 4 / 25A	3 x 1,5 / 10A (3)
Tension 400V - III + N + T		Nº x mm <sup>2</sup> / A	5 x 2,5 / 16A	3 x 1,5 / 10A (4)
DIMENSIONS / PACKING DIMENSIONS				
Net / gross width		mm	680 / 710	
		inch	26,77 / 27,95	



Net / gross depth	mm	775 / 832
	inch	30,51 / 32,76
Net / gross height	mm	1.056 / 1.141
	inch	41,57 / 44,92
Net / gross weight	Kg	92,6 / 104,1
	lb	204,15 / 229,50
<b>OTHERS</b>		
Sound level	dB	62

- (1)- Configurable through a terminal system
- (2)- single motor for drum and fan
- (3\*) Connect 2 phases and ground
- (4\*) Connect phase, neutral and ground

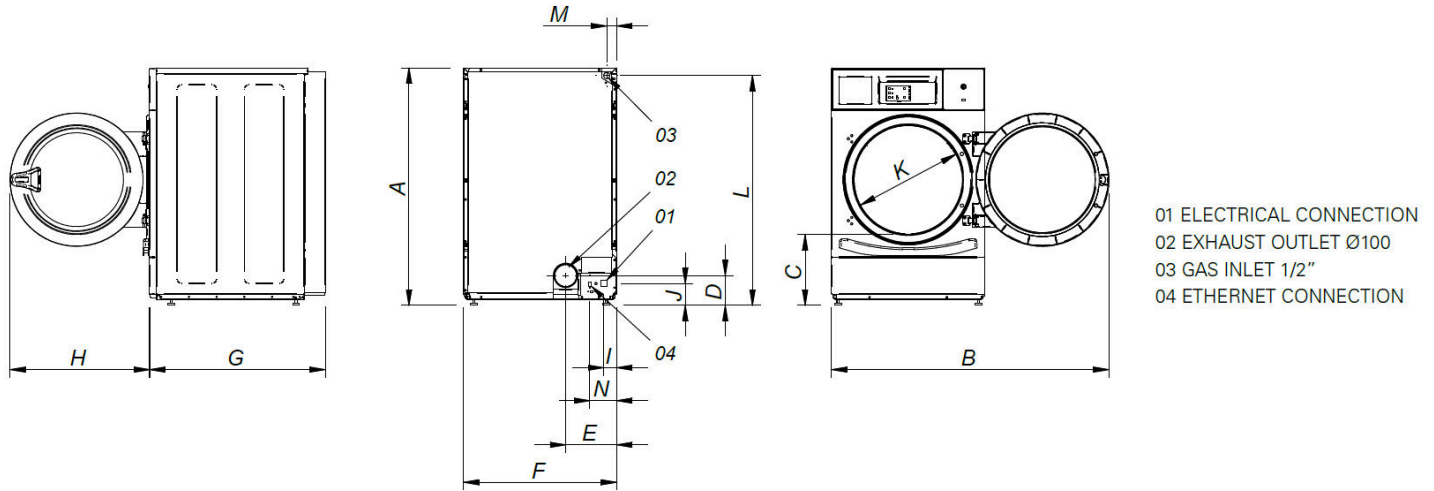

	A	B	C	D	E	F	G	H	I	J	K	L	M	N
DPR-8 ET2	1056	1227	320	140	226	680	722	615	57	91	480	1015	50	118
DPR-10 ET2	1056	1227	320	140	226	680	775	615	57	91	480	1015	50	118

