



R2D25-200 GOLD GOLD ø 250 mm wall ironers



ELECTRONIC CONTROL

BM control: simple and user friendly with an AUTO mode, automatic management of ironing speed according to the selected temperature.
Digital speed and temperature display



FEATURES

Large roll contact area with the linen
Operation mode identical to a flatwork ironer: no roll lifting, more ergonomic
Models equipped as standard with Nomex belts, suction and variable speed inverter: more productivity
Adjustable speed and temperature



ROBUSTNESS

Nomex coating as standard: resistant to high temperatures
Panels in grey skinplate and stainless steel
Wooden feeding board
New kinematics, better reliability
Industrial components, more durable



EFFICIENCY

Acoustic comfort : <55 dB
Minimum space requirement: space saving, suitable for small spaces
Ideal for processing small quantity of flat linen in facilities like restaurants, guest rooms, etc.



MAINTENANCE

Easy installation : requires only an electrical connection
Easy access on both sides for maintenance
Quick and easy dismantling of bearings



OTHERS

Front feeding and return
Roll ø 250 mm
Working widths: 1.400 and 2.000 mm
Electric heating
CE certification



OPTIONS

- 440V III 60Hz No neutral (marine) - ø 250 mm only

GENERAL DETAILS		UNIT.	R2D25-200 GOLD
Theoretical production 20-25% humidity		Kg/h	50
		Lb/H	110,23
Roll Ø		mm	250
		Inch	9,84
Working width		mm	2.000
		Inch	78,74
Working speed		m/min	1,5-6
		ft/mn	4,9 - 19,6
-		YES	
Electronic control	-		YES
-		NO	
POWER			
Heating power		Kw	12
Roll motor power		Kw	0,18
Fan motor power		Kw	0,12
Total electric power		Kw	12,3
CONNEXIONS			
Tension 230V I + N + T		n° x mm² /A	N/A
		n° x AWG/A	N/A
Tension 230V III + T		n° x mm² /A	4 x 10 / 40A
		n° x AWG/A	4 x 7 / 40A
Tension 400V III + N + T		n° x mm² /A	5 x 4 / 20A
		n° x AWG/A	5 x 11 / 20A
DIMENSIONS / PACKING DIMENSIONS			
Net width / Gross width		mm	2.523 / 2.490
		Inch	97 / 98
Net depth / Gross depth		mm	484 / 540
		Inch	19 / 21
Net height / Gross height		mm	985 / 1.130
		Inch	39 / 44
Net weight / Gross weight		Kg	184 / 204
		Lb	406 / 450
Volume		m³	1,20 / 1,52
		fr3	42,48 / 53,66
OTHERS			
	Nº	1	
	mm	80	
	Inch	3,15	
	m³/h	500	
	cfm	294	
Noise level		dB	60

*Dismantling of the extraction on left side for packaging



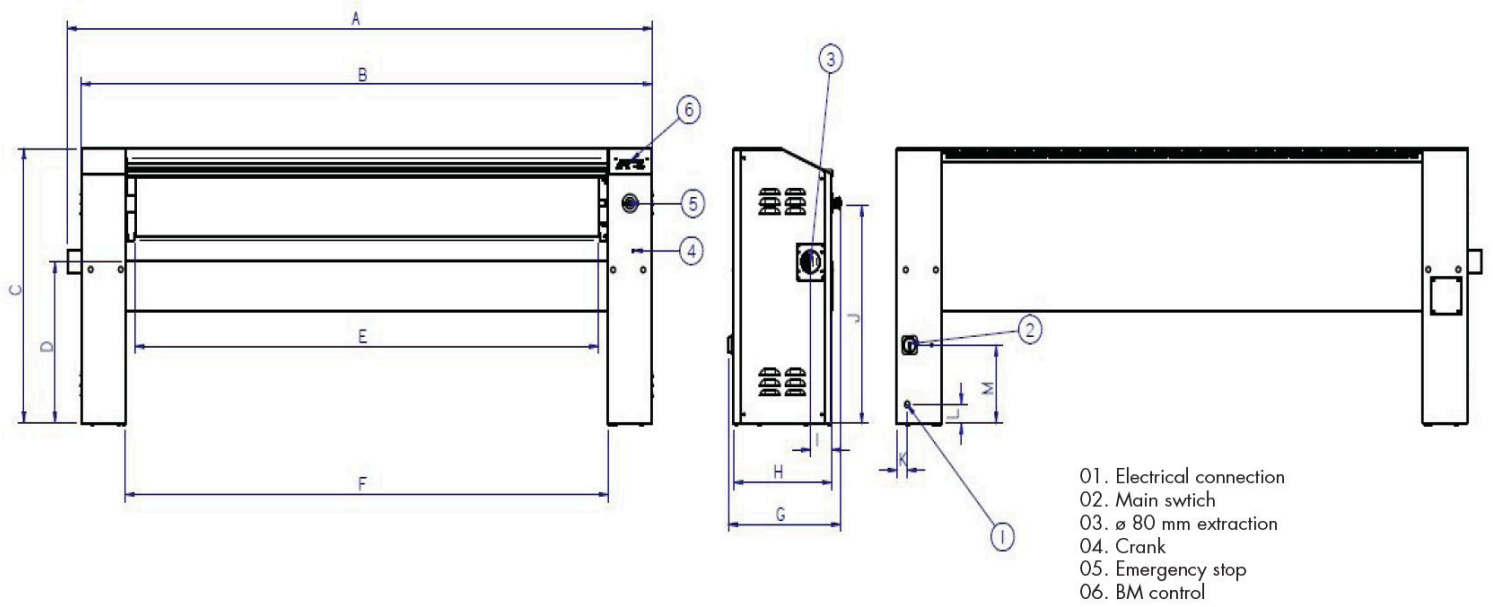

	A	B	C	D	E	F	G	H	I	J	K	L	M
R2D25/140 GOLD	1.923	1.862	985	610	1.400	1.480	484	423	91	791	45	75	287
R2D25/200 GOLD	2.523	2.462	985	610	2.000	2.080	484	423	91	791	45	75	287