



SPE800-3300

SPE compact ironers

FEATURES

SPE models are ironers that dries, irons and folds with a lengthwise and crosswise folder. They can be equipped with a stacker as option: 2 models available.

- Roll dimensions: working width 2m60 and 3m30, ø 600, 800 or 1000 mm
- 1 or 2 working lanes: one for bedsheets and two lanes for table cloth and small pieces.
- Length fold (1 or 2 folds) and crossfold (up to 3 folds)
- Folding by photocells and compressed air.
- 2 types of stacker as option, with possibility to program the number of stacked items. The stacker can be located on either side to the machine.
- Frequency inverter.
- Feeding and ironing by Nomex quality belts.
- Panels in white painted steel.
- Polished steel roll with fingers guard.
- Touch screen control: programs can be created, with temperature and speed control:
 - between 3 and 10 m/min (ø 600 mm),
 - between 3 and 13 m/min (ø 800 mm),
 - between 4 and 18 m/min (ø 1000 mm)
- Big output capacity: depending on the residual moisture of the linen straight away from a high spin washer:
 - up to 140 kg/h (ø 600 mm)
 - up to 220 kg/h (ø 800 mm)
 - up to 290 kg/h (ø 1000 mm)
- Electric, gas or steam heating
- Powerful exhaust system
- Compressed air connexion required: pressure 6,5 bar



OPTIONS

- Compact side stacker (stacking by blades)
- Roll-off side stacker (stacking by dragging)
- Vacuum belts to help linen feeding
- Automatic 1 lane clamp feeder (requires vacuum feeding belts option)
- By pass for rear exit
- Rear exit with table 800 mm height + by pass
- 2 lanes rear collector for small items (requires by-pass option)
- 4 lanes rear collector for small items (requires by-pass option)
- Double air pressure for thick linen
- Dirty or torn linen rejection system (buttons)
- 4 lanes for lengthfolding
- Low side exit table (without stacker) H=480 mm
- Motorised high side exit table (without stacker) H=805 mm
- Rotating control panel
- Remote service
- Other tension than 400V III+N 50Hz
- Maritime packing pour COMPACT SPE
- Maritime packing for side stacker
- Maritime packing fro ROLL OFF
- Maritime packing for 2 lanes collector
- Maritime packing for 4 lanes collector

GENERAL DATA	UNIT.	SPE800-3300
Theoretical production* elec/steam/atm. Gas heating	Kg/h	180-220
Theoretical production* radiant gas burner	Kg/h	216-264
Ø Roll	mm	800
Working width	mm	3.300
Height floor-feeding	mm	1.050
Working speed	m/min	3-14
Control type	-	Digital
No. of programs	Nº.	20
MAIN FUNCTIONS		
Drying	-	YES
Ironing	-	YES
Longitudinal folding	-	YES
Cross folding	-	YES
Lateral stacking (Roll-Off or compact stacker)	-	OPT
FOLDING		
1 lane - lengthfold	Nº.	1-2
1 lane - crossfold	Nº	1-2-3
2 lanes - lengthfold	Nº	1-2
2 lanes - crossfold	Nº	1-2
POWER		
Electric model - Consumption	A	104
Electric model - Heating power	kW	72
Electric model - Total electrical power	kW	75,5
Steam model - Consumption	Kg/h	185
Steam model - Power (max 12 bar)	kW	110
Steam model - Total electrical power	kW	3,5
Liquefied gas (LPG) model - Consumption	m³/h	4,6
Liquefied gas (LPG) model - Power	kW	124,1
Natural gas (NG) model - Consumption	m³/h	13,2
Natural gas (NG) model - Power	kW	124,7
Gas LPG / NG model - Total electrical power	kW	3,5
CONNECTIONS		
Ø Gas inlet	BSP	1"
Ø Steam inlet (12 bar max.)	BSP	1"
Ø Condensed (steam models)	BSP	1/2"
Ø Air inlet	mm	12
DIMENSIONS		
Net width / gross width	mm	4.440 / 4.600
Net depth / gross depth	mm	2.210 / 2.280
Net height / gross height	mm	2.300 / 2.230
Net weight / gross weight	Kg	3.630 / 4.230
Volume	m³	22,57 / 23,39
OTHERS		
Exhaust outlet	Nº	2
Exhaust outlet Ø	mm	160
Air extraction flow rate	m³/h	2 x 1.400
Air consumption (6.5 bar)	NI/h	19.000
Noise level	dB	<80

*50% residual moisture, 140gr / m2 of cotton,100% roll use



Compact stacker
(roll-off)

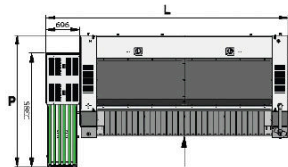

Standard side
stacker

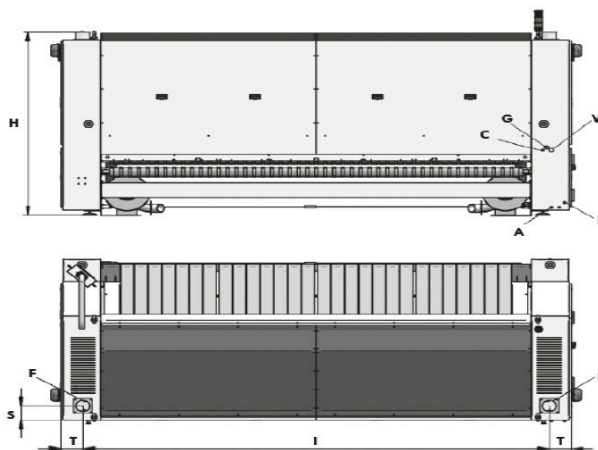
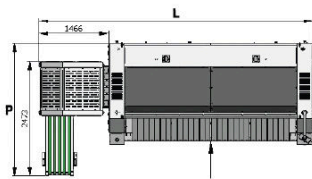

- A. Compressed air inlet
- C. Condensed discharge
(steam model)
- E. Electrical connection
- F. Fumes extraction
- G. Gas inlet
- V. Steam inlet

Compact stacker (roll-off)

Standard stacker

	Compact stacker (roll-off)		Standard stacker		
	L	P	L	P	
SPE800-2600	4.425	2.385	SPE600-2600	5.105	2.476
SPE800-3300	5.125	2.385	SPE600-3300	5.805	2.476

