



# R2D25-200 N

## ø 250mm wall ironers



### ELECTRONIC CONTROL

Simple and user friendly: digital screen, precise control of temperature  
Preset ironing speeds, not adjustable



### FEATURES

Large roll contact area with the linen  
Automatic roll lifting control by foot photocell detection  
Two available models:

- Standard: roll with cotton polyester coating
- Nomex: roll with Nomex coating



### ROBUSTNESS

Nomex coating: resistant to high temperatures  
Panels in grey skinplate and stainless steel  
Wooden feeding board  
New kinematics: better reliability  
Industrial components: more durable



### EFFICIENCY

Acoustic comfort : 55 dB  
Minimum space requirement: space saving, suitable for small spaces  
Ideal for processing small quantity of flat linen in facilities like restaurants, guest rooms, hostels, etc.



### MAINTENANCE

Easy installation : requires only an electrical connection  
Easy access on both sides for maintenance  
Quick and easy dismantling of bearings



### OTHERS

Front feeding and return  
Roll ø 250 mm  
Working widths: 1.400 and 2.000 mm  
Electric heating  
CE certification



### OPTIONS

- FP Pedal control instead of photocell R2D25 (except GOLD)
- 400-230V +N+T 60Hz - ø 250 mm only
- 440V III 60Hz No neutral (marine) - ø 250 mm only

GENERAL DETAILS		UNIT.	R2D25-200 N
Theoretical production 20-25% humidity		Kg/h	35
		Lb/H	77,16
Roll Ø		mm	250
		Inch	9,84
Working width		mm	2.000
		Inch	78,74
Working speed		m/min	4,2
		ft/mn	13,77
	-	YES	
Electronic control	-		YES
	-	AUTO	
POWER			
Heating power		Kw	12
Roll motor power		Kw	0,18
Fan motor power		Kw	-
Total electric power		Kw	12,18
CONNEXIONS			
Tension 230V I + N + T		n° x mm <sup>2</sup> /A	N/A
		n° x AWG/A	N/A
Tension 230V III + T		n° x mm <sup>2</sup> /A	4 x 6 / 32A
		n° x AWG/A	4 x 9 / 32A
Tension 400V III + N + T		n° x mm <sup>2</sup> /A	5 x 4 / 20A
		n° x AWG/A	5 x 11 / 20A
DIMENSIONS / PACKING DIMENSIONS			
Net width / Gross width		mm	2.462 / 2.490
		Inch	97 / 98
Net depth / Gross depth		mm	484 / 540
		Inch	19 / 21
Net height / Gross height		mm	985 / 1.130
		Inch	39 / 44
Net weight / Gross weight		Kg	164 / 184
		Lb	362 / 406
Volume		m <sup>3</sup>	1,17 / 1,51
		fr3	41,32 / 53,33
OTHERS			
	NO	-	
	mm	-	
	Inch	-	
	m3/h	-	
	cfm	-	
Noise level		dB	55



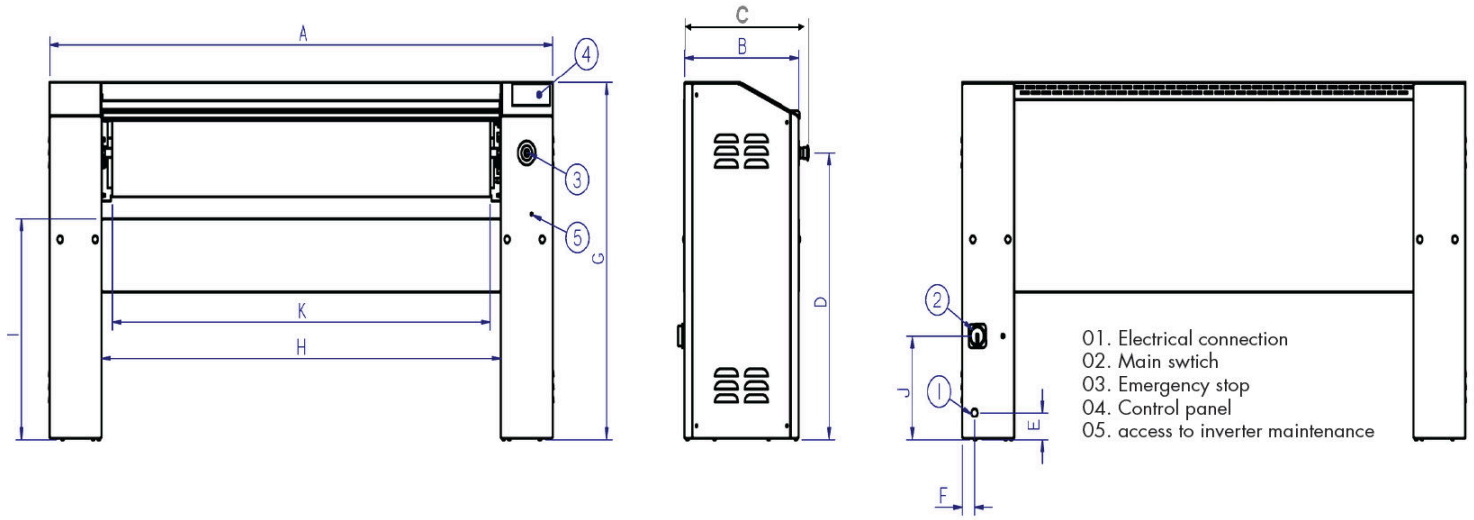

	A	B	C	D	E	F	G	H	I	J	K
R2D25/100	1.462	423	484	791	75	45	985	1.079	610	287	998
R2D25/120	1.662	423	484	791	75	45	985	1.279	610	287	1.198
R2D25/140	1.862	423	484	791	75	45	985	1.479	610	287	1.398
R2D25/200	2.462	423	484	791	75	45	985	2.079	610	287	1.998

