

DD-11 BRONZE EM BRONZE dryers



ELECTRONIC CONTROL

Easy-to-use electronic control with push buttons to control temperature and time



FEATURES

Reversing drum action as standard
Stainless steel drum as standard
Frequency inverter as standard



EFFICIENCY

DOUBLE FLOW - mixed axial-radial airflow
Big fluff filter as drawer



VERSATILITY

Make to order - customisation
OPL > Multivending - Standard OPL model easily trasformable to coin laundry uses



ERGONOMICS

Drawer as fluff filter, stainless steel mesh
Big door diameters
Opening sense of door adjustable on site



MAINTENANCE

Hinged control panel: easy and ergonomic access
Technical menu: statistics, data recovery for after-sales service, software updates, etc.
Easy access to components



OTHERS

Grey skinplate outer casing, stainless steel look
NEW: transmission by gear motor on models DD-45 to 80
SOFT DRY - new drum with stamped holes
COOL DOWN - anti-wrinkle at the end of the cycle
Electric, gas or steam heating
CE approved



OPTIONS

- DG Double doorglass DD-11-28
- NG Natural gas heated tumble dryer (LPG as standard)
- RD Opposite door opening 11-35
- BMS New display for EM programmer
- AF Back panel with air filter from 11 to 35
- F06 Fluff filter with grid 0,6mm (standard is 0,3mm)
- F12 Fluff filter with grid 1,2 mm (standard is 0,3 mm)
- SSC Stainless steel outer casing 11
- SSF Stainless steel front panel 11, 14, 18
- BSS Stainless steel steam battery 11-14-18
- WB Wooden packing 11
- 400V 3N 60 Hz DD--11-35
- 230V 3~ 50 Hz DD-11, 14, 18 E
- 230V 3~ 60 Hz DD-11,14, 18 E
- 230V 3~ 60 Hz DD-11,35 G/S
- 230V 1N 50 Hz DD-11 E
- 440/480V 3~ 60 Hz DD- 11,18
- Several payment systems for self-service

CAPACITY & DRUM		UNIT.	DD-11 BRONZE EM
Capacity 1/18		Kg	11,7
		lb	25,7
Capacity 1/20		Kg	10,5
		lb	23,1
Ø Drum		mm	750
		inch	29,5
Drum length		mm	475
		inch	18,7
Drum volume		l	210
		cu ft	7,41
Ø Door hole		mm	574
		inch	22,6
Door center height		mm	976
		inch	38,4
Height from floor to bottom of door		mm	618
		inch	24,33
ELECTRIC HEATING			
Evaporation capacity		L/h	9,3
		US gallon/h	2,46
Hourly output		Kg/h	20,3
		lb/h	44,75
Installed heating power		kW	12
Installed electrical power		kW	12,67
Drum motor power		kW	0,37
GAS HEATING			
Evaporation capacity (gas model)		L/h	14,5
		US gallon/h	3,83
Hourly output (gas model)		Kg/h	28,60
		lb/h	63,05
Installed gas heating power		kcal/h	17727
		Btu/h	69996
Installed gas heating power		kW	20,5
Installed electrical power		kW	0,67
Instant propane gas consumption (G31)		Kg/h	1,76
		lb/h	3,88
Instant natural gas consumption (G20)		m ³ /h	2,17
		cfm	1,28
Ø Gas inlet		BSPP ISO 228-1	1/2"
STEAM HEATING			
Installed steam heating power		kW	30
		Btu/h	102364
Installed electrical power		kW	0,67
Steam consumption (8 barG) - Standard		kg/h	53
Steam consumption (116 psiG)		lb/h	63,8
Steam pressure		barG	6 - 9
		psiG	87 - 130,5
Standard steam inlet - outlet		BSPT- ISO7.1	3/4"
Steam inlet - condensate outlet		NPT ANSI B1.20.1 Tapered	3/4"
Steam consumption (5 barG) - Low Pressure		kg/h	57
Steam consumption (72,5 psiG) - Low Pressure		lb/h	68,7
Steam pressure (low pressure)		barG	3 - 6
		psiG	43,5 - 87
Low pressure steam inlet - outlet		BSPT- ISO7.1	1"
VENTILATION			
Fan motor power		kW	0,25
Nominal air flow rate		m ³ /h	850
		cfm	500



Ø Fume exhaust	mm	200	
	inch	7,87	
HEAT EMISSION			
Maximum total heat emission	kW	1,2	
	Btu/h	4097	
Max. front heat emission	kW	0,8	
	Btu/h	2868	
CONNECTIONS			
Tension 230V - I + N + T	Nº x mm² / A	E	G / S
Tension 230V - III + T	Nº x mm² / A	3 x 25 / 63A	3 x 1,5 / 16A
Tension 400V - III + N + T	Nº x mm² / A	4 x 10 / 40A	3 x 1,5 / 16A
Tension 400V - III + N + T	Nº x mm² / A	5 x 4 / 25A	3 x 1,5 / 16A
NET DIMENSIONS / PACKING DIMENSIONS			
Net / gross width	mm	785 / 865	
	inch	30,9 / 34,1	
Net / gross depth	mm	855 / 940	
	inch	33,7 / 37	
Net height / gross height (* without heating)	mm	1.694 / 1.840	
	inch	66,7 / 72,4	
Net / gross weight	Kg	172 / 180	
	lb	379 / 397	
OTHERS			
Sound level	dB	64	

* Sizes Gas or steam 45 kg model same as model 80 kg (incorporates the batteries at the back)

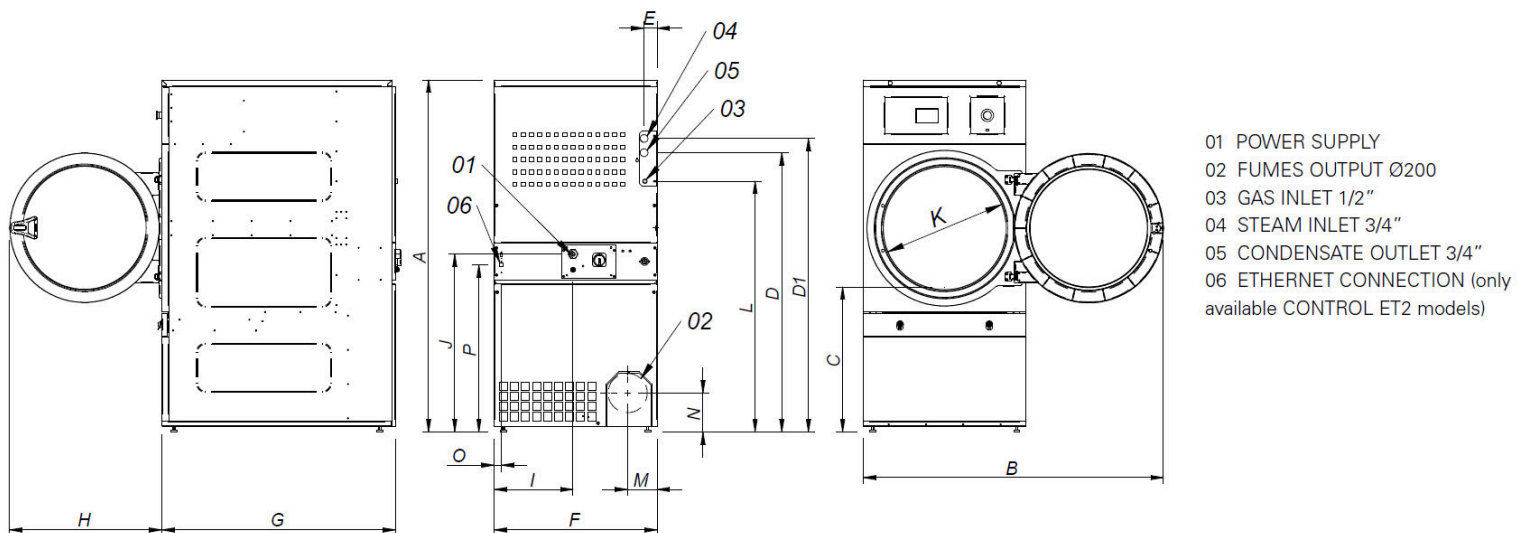

	A	B	C	D	D1	E	E1	F	G	H	I	J	K	L	M	N	O	P
DD-11	1694*	1447	689	1354	1422	68	68	785	855	735	380	870	575	1226	133	180	35	805
DD-14	1694*	1447	689	1354	1422	68	68	785	989	735	380	870	575	1226	133	180	35	805

* Measurement with legs mounted (30mm)

