

COMPACT BLUEWASHBOX

BlueWash Solution

FEATURES

INCLUDED MACHINES:

Compact laundry container consisting of:

- 18 kg washer
- 10 kg washer
- 18 kg dryer

Electric boiler for hot water (capacity 80 litres).

Possibility of incorporating the new DANUBE LAUNDRY KIOSK central pay with a 12" digital screen, allowing contactless payments with cards or smart devices (NFC).

Reduced installation power, only 17kW.

A single connection point for the electricity grid, water and drainage at the bottom of the container. Large surface area to adapt to the installation.

Winter pack option recommended for ambient temperatures below -10°C.

EASY TOUCH 2

All machines are controlled by EASY TOUCH 2, with 7" colour touch screen, fully programmable and user-friendly. 37 languages available

CONNECTIVITY

DANUBE ONLINE communication - Standard and free connectivity.

DANUBE ONLINE IoT allows you to manage your compact laundry, creating discount programmes, view statistics, etc.

Remote payment via **DANUBE LAUNDRY APP**, for payments via QR code, promotions and machine booking.

VERSATILITY

Custom-made: the Compact Bluewashbox can be customized. Ready to be easily transported by forklift from below or by crane via 4 lifting points.

SEVERAL APPLICATIONS

Gas stations, car wash station, mining or oil fields, public parking, mass events, supermarkets, investors, campsites, natural disasters, fire zones, etc.

ROBUSTNESS

Structure made of galvanised steel with skinplate fairing. Safety glass composed of 5mm glass, polyvinyl butyral film and another 5mm glass film.

MAINTENANCE

Easy and ergonomic access for technicians and chemicals through the side and rear panels.

Equivalence of parts: many key parts are identical for all models (contactors, electronic components, motor, etc.).

Easy access to components for reparability through the hinged front, side and rear panels.

Technical menu: telemetry, fault diagnosis, etc.



OPTIONS

- KSH Integrated central pay DANUBE LAUNDRY KIOSK 12" SH
- FL Front built-in lighting
- RL Back built-in lighting
- SP Solar panels
- MP Container packing
- WP Winter pack
- PD Domatics system
- Front security shutter
- Option 230V/III/60Hz
- Several payment systems for self-service

GENERAL DETAILS	UNIT.	COMPACT BLUEWASHBOX
Payment Centre (12" kiosk)	-	OPT.
Coiners (3 units)	-	OPT.
Coin box (3 units)	-	OPT.
Winter Pack	-	OPT.
Solar panels	-	OPT.
Front / rear lighting	-	OPT.
Domotics pack	-	OPT.
Front security shutter	-	OPT.
CONNECTIONS		E
Tension 400V III 50Hz	Nº x mm ² /A	4x4+T - 32A
Tension 230V III 60Hz	Nº x mm ² /A	3x10+T - 50A
Water inlet	inch	3/4"
Water pressure	Kgs/cm ²	2-4
Maximum water consumption*	Lit/h	120
Drain	inch	3"
Drainage capacity	Lit/h	200
Network	Ethernet	RJ45
DIMENSIONS / PACKING DIMENSIONS		
Net Width/Gross width	mm	2877 / 2990
Net Depth/Gross depth	mm	1974 / 2100
Net Height / Gross height	mm	2235 / 2562
Net weight / Gross weight	Kg	1500 / 1650
Volume	m ³	12,7 / 16

* COIN program



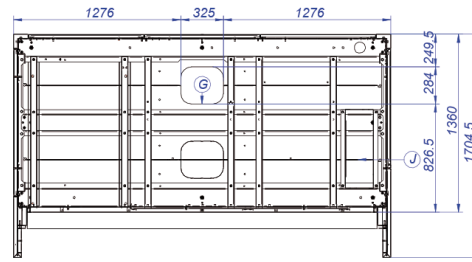
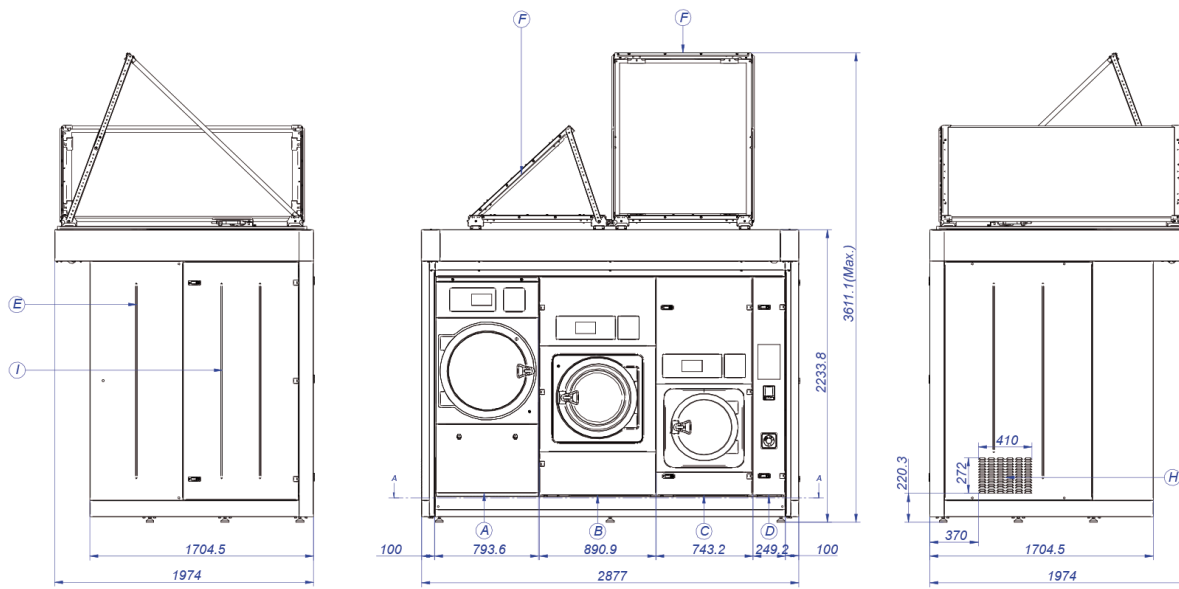

CORTE A-A

- A. 18 kg dryer
- B. 18 kg washer
- C. 10 kg washer
- D. Central pay station
- E. WiFi antenna
- F. Solar panels
- G. Water access
- H. Dryer air outlet
- I. Maintenance service door
- J. Chemicals dispenser

