



FEATURES

MAN / MAN-C

- Fully automatic cycle by electronic card
- Steaming and drying time controlled by 3 timers.
- 9 different cycles available
- Adjustable shoulder and sleeve widths
- Rotation of dummy support at 360°
- Does not require compressed air

MAN (WITHOUT BOILER)

- Without steam boiler, to be connected to a central steam supply
- It needs a steam inlet and outlet
- Can be installed with steam generator SB-24 - 12 kw
- Voltage 400 V III +N / 230 V III 50-60 Hz

MAN-C (SELF-CONTAINED)

- Complete with built-in steam boiler 18 lt
- Automatic water feeding
- Automatic pressure control (4,5 bar)
- Voltage 400 V III +N / 230 V III 50-60 Hz.

MAN-SHIRT

- For both water washed or dry cleaned shirts, anoraks or jackets
- Without boiler: to be connected to a central steam supply
- Can be installed with a steam generator SB-24 - 22 KW
- Two sleeve stretchers with double independent traction
- Front heated and reclining panel
- Automatic carriage with photocell for the stretching of side and back part
- Powerful 3 HP fan
- Button placket part of the dummy with suction
- Electronic card featuring nine programs for an automatic working cycle
- Pneumatically operated air flow regulation device
- Manually adjustable shoulder width
- Pneumatically adjustable height of dummy, air working pressure: 5-6 bar, air consumption: 20 NI/min
- Voltage 400V III+N / 230V III 50-60 Hz

MAN-COAT

- Automatic tensioning finisher for classic coats, overcoats and similar garments
- Without boiler: to be connected to central steam supply
- Working cycle by electronic card with 9 stored finishing programs, very easy to modify
- Telescopic shape till 1.500 mm
- Special 350° revolving "body" form plus automatic "front & rear" paddle clamps
- Sensor for the "automatic research of the height" of the garment
- Double "antistretching" system in large (waist) and in height (length)
- Mechanical adjustable shoulder group and dedicated "collar" clamp
- Damper for air-volume regulation
- To be connected to compressed air supply, air working pressure 5-6 bar, air consumption 8/9 NI/min.
- Can be installed with steam generator SB-24 - 22 kw
- Voltage : 400V III+N / 230V III 50-60 Hz



GENERAL DETAILS	UNIT.	MAN-C
Boiler	-	YES
Boiler capacity	L	
Group of iron	-	-
Steam gun	-	OPT
POWER		
Pump motor	HP	0,8
Boiler heater	kW	12
Fan motor	kW	1
CONNECTIONS		
Ø Water inlet	BSP	3/8"
Ø Boiler exhaust (mod. with boiler)	BSP	1/2"
Ø Steam inlet	BSP	-
Ø Condensate outlet	BSP	-
Steam pressure	bar	4,5
Steam consumption	Kg/h	10-15
Ø Air inlet	BSP	-
Ø Air outlet	mm	-
Air pressure	bar	-
Air Consumption	NI/min	-
DIMENSIONS / PACKING DIMENSIONS		
Net width / Gross width	mm	1.360 / 1.390
Net depth / Gross depth	mm	610 / 640
Net height / Gross height	mm	1.780 / 1.910
Net weight / Gross weight	kg	130 / 151
Volume	m ³	1,48 / 1,70
OTHERS		
Voltage	V	230/400V 3~ 50-60
Sound level	dB	70



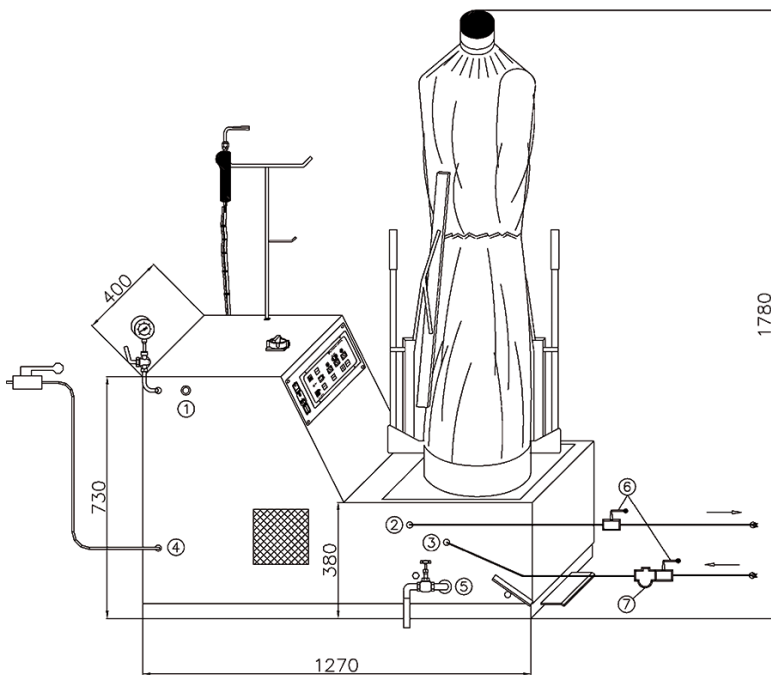

1. Power supply
2. Steam connection 3/8"
3. Condensates return 3/8"
4. Water inlet 3/8"
5. Boiler drain 1/2"
6. Shut-off valve
7. Check valve

